

# VIPP263

## SALT & PEPPER

### DESIGNER

Vipp Design Lab, 2010

### COUNTRY OF ORIGIN

Design: Denmark

Production and assembly: PRC



### PRODUCT DESCRIPTION

The Vipp salt and pepper mill is constructed with a swivel top in solid stainless steel and a durable and adjustable ceramic grinder with a refined grinding sound. The grinders are available individually or as a set together with a practical base in powder-coated aluminium. The rubber element of the base can be easily removed for cleaning.

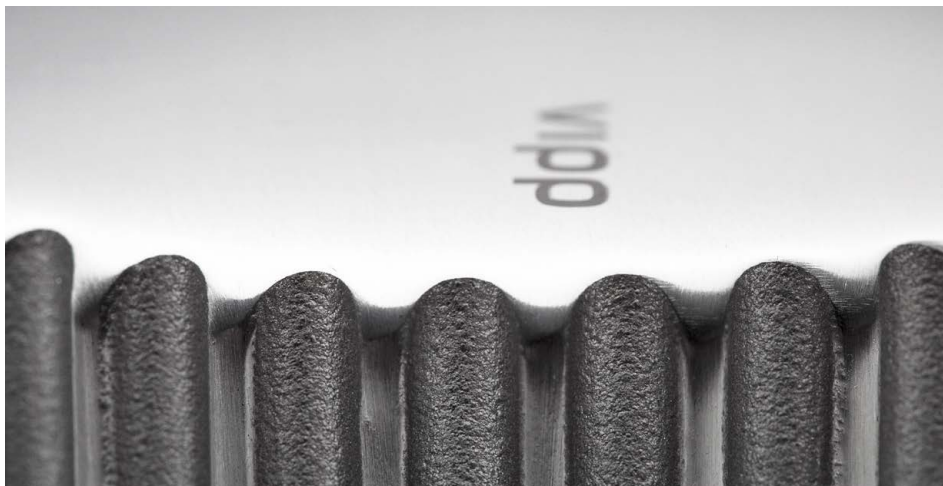

### CARE INSTRUCTIONS

Stainless steel surfaces should be cleaned and polished with a microfiber cloth, glass cleaner or other non-abrasive and gentle cleaning agents.

- Lacquered surfaces should be cleaned with a moist cloth.
- Grinder mechanism: Can be cleaned by grinding coarse salt
- For a more thorough cleaning, unscrew the grey adjusting wheel. Then take out the ceramic cone and let it soak in hot water. Make sure that the cone is completely dry before mounting and grinding again. Let it dry at least 24 hours.

### WARRANTY

2 years warranty. The warranty presupposes rightful use as described in Vipp's care instructions, with reservations for normal wear and tear. Please see Vipp's care instructions at [www.vipp.com](http://www.vipp.com).

# VIPP263

## SALT & PEPPER

### MATERIALS

Top: Cast stainless steel, laser engraved logo

Body: Powder coated stainless steel

Interior: Silicone

Grinder: Crush Grind, Ceramic grinder

### MANUFACTURING

Plastic parts: Injection molding

Body: Forging, welding, polishing and/or painting

Interior: Compression moulding

Bottom: Overmolding

### DIMENSIONS

Height: 115mm

Diameter: ø65mm

### VERSIONS

Black (CWS 85609 Schwarz metallic)

White (CWS 9898849 RAL 9016)

### PRODUCT CERTIFICATION

LGBD approved

### PACKAGING/FSC

Single grinder Packaging 109 x 109 x 160

Grinder set 200 x 122 x 160

FSC papier

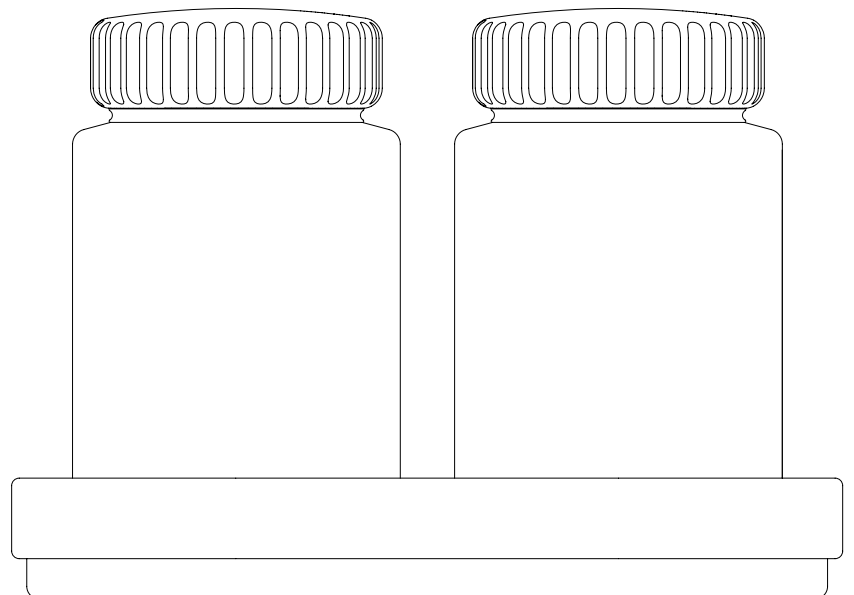
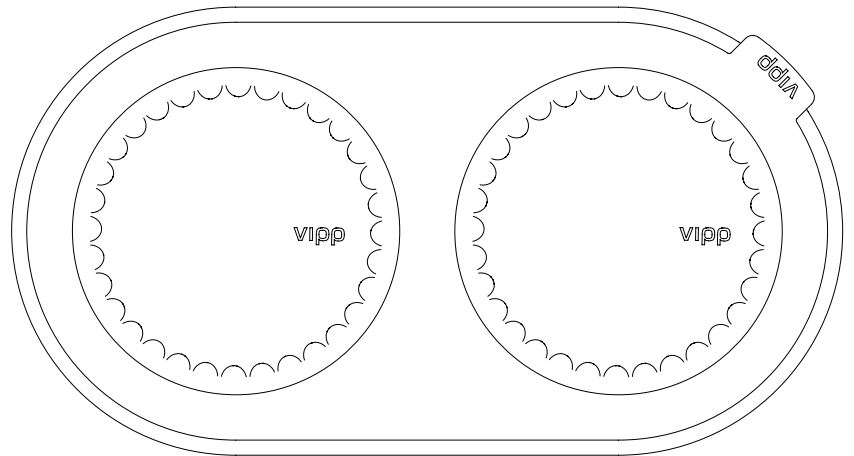

# VIPP263

## SALT & PEPPER

### ASSEMBLY

### INSTRUCTIONS

#### HOW TO USE

- 1 - Pull off the top piece
- 2 - Fill cannister with salt or pepper
- 3 - Specify the coarseness by adjusting the grey wheel clockwise for finer, anti-clockwise for coarser

#### HOW TO CLEAN

##### With salt

In most cases you can clean your mill by grinding some coarse salt

##### With water

For a more thorough cleaning, unscrew the grey adjusting wheel

- take out the ceramic cone
- let the cone soak in hot water

Make sure that the cone is completely dry before mounting and grinding again. Let it dry at least 24 hours.

